

9016015COM Fireplace Mantel

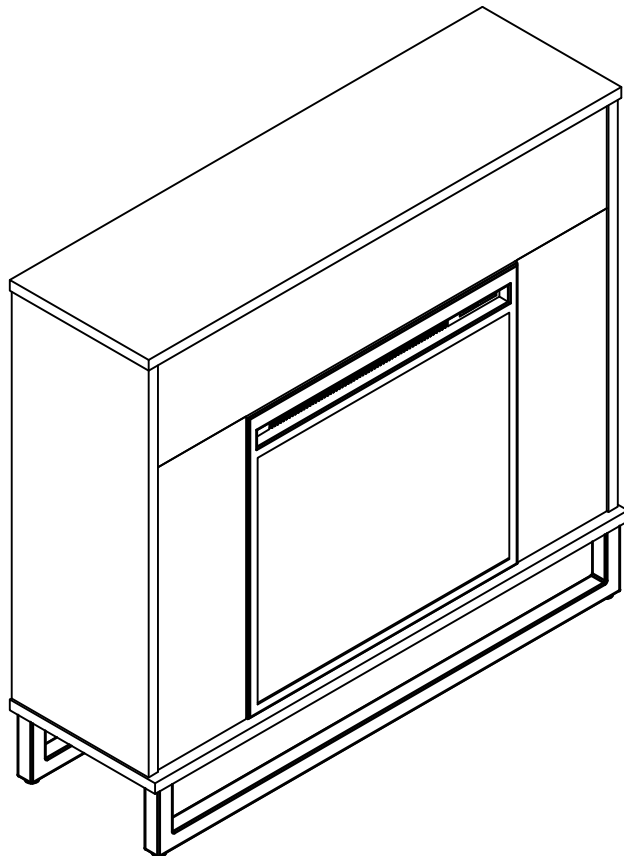

Date of Purchase ___ / ___ / ___
Lot Number:

B349016015COM0



Do Not Return This Product!
Contact our customer service team for help first.
Call: 1-800-489-3351 (toll free)
Monday-Friday 9am - 5pm CST
Visit: www.ameriwoodhome.com

THIS INSTRUCTION BOOKLET CONTAINS **IMPORTANT** SAFETY INFORMATION. PLEASE READ AND KEEP FOR FUTURE REFERENCE.

Secure Your Furniture

Keep your home and family safe with the wall anchor kit that is included with the product.

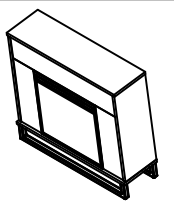

Serious or fatal crushing injuries can occur from tipping furniture.

WARNING: Manufacturer assumes no liability for improper installation or excessive loads placed on screws or bracket. This wall anchor is not a substitute for proper adult supervision.

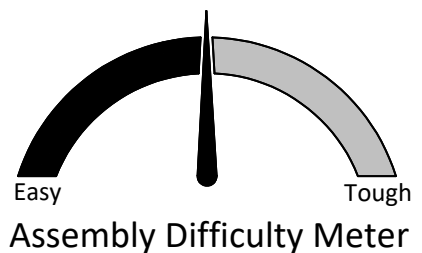

Follow Ameriwood Home



Contact Us!

Do NOT return this product!

Contact our friendly customer service team first for help.

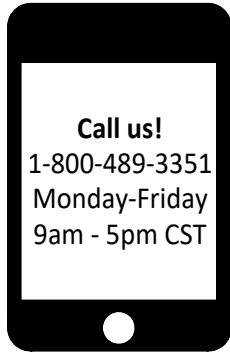

Visit ameriwoodhome.com to view the limited warranty valid in the U.S. and Canada.

Assembly Tips



Helpful Hints

PEOPLE NEEDED FOR ASSEMBLY: 1-2

- Open your item in the area you plan to keep it to avoid excessive heavy lifting.
- Identify, sort and count the parts before attempting assembly.
- Compression dowels are lightly tapped in with a hammer.
- Slides are labeled with a **R** (right) and **L** (left) for proper placement.
- Make sure to always face the point on the top of the Cam Lock towards the outer edge.
- Use all the nails provided for the back panel and spread them out equally.
- Back panel must be used to make sure your unit is sturdy.
- Do NOT use harsh chemicals or abrasive cleaners on this item.
- Never push, pull, or drag your furniture.

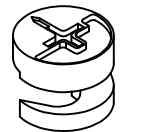

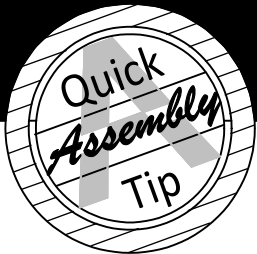

Before You Start



- ✓ Read through each step carefully and follow the proper order
- ✓ Separate and count all your parts and hardware
Parts are labeled on the surface or edge of the part
- ✓ Give yourself enough room for the assembly process
- ✓ Have the following tools: Flat Head Screwdriver, #2 Phillips Head Screwdriver and Hammer
- ✓ Caution: If using a power drill or power screwdriver for screwing, please be aware to slow down and stop when screw is tight. Failure to do so may result in stripping the screw.

Cam Lock Fastening System

This Cam Lock Fastening System will be used throughout the assembly process.

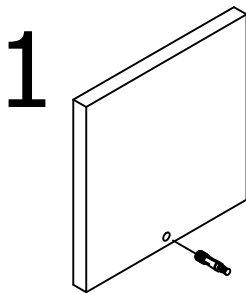

1 Press CAM BOLT into hole.

2

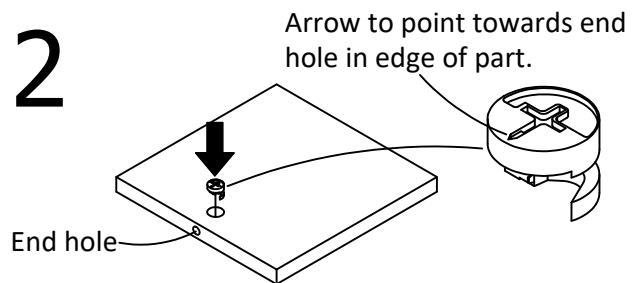

Press CAM LOCK into hole.

3

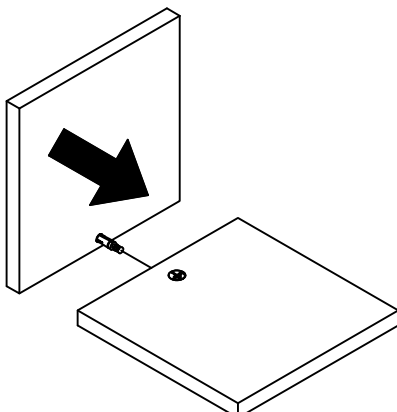

Press parts together so CAM BOLT inserts into edge hole.

4

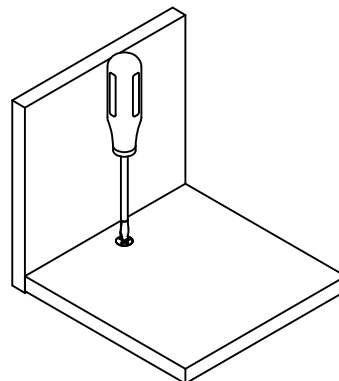

Using a screwdriver, turn the CAM LOCK clockwise to lock the CAM LOCK and CAM BOLT into their holes and fastening parts together.

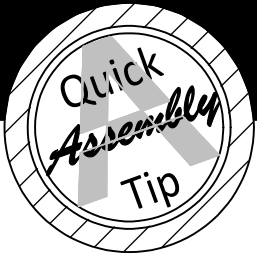

Before You Start

Please Note:

You may need to lightly tap the wood dowels into the holes during your assembly process.

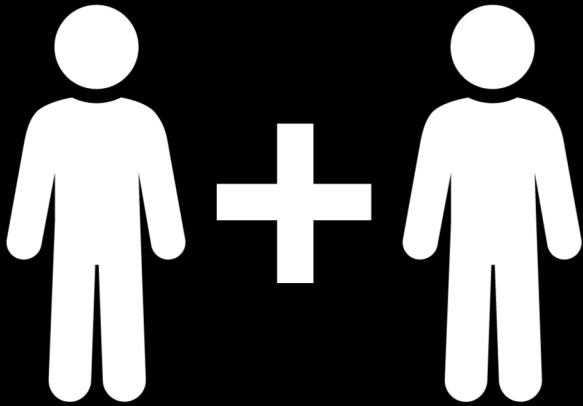
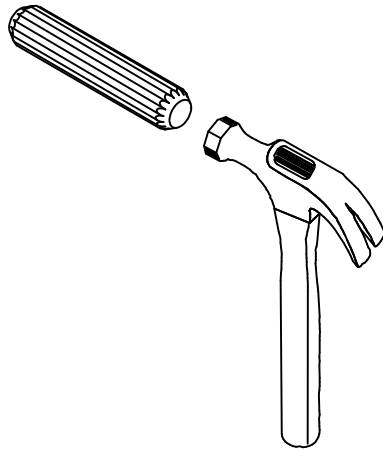

2 PEOPLE NEEDED FOR ASSEMBLY

**2 PERSONAS NECESITADAS
PARA LA ASAMBLEA**

**2 PERSONNES NÉCESSAIRES
POUR L'ASSEMBLAGE**

CAUTION: Failure to use 2 people for assembly could result in unit damage or personal injury.

PRECAUCIÓN: Si no se utilizan 2 personas para el ensamblaje, se pueden producir daños en la unidad o lesiones personales.

ATTENTION: Échec d'utiliser 2 personnes pour l'assemblage peut causer du dommage au meuble ou causer des blessures.

Board Identification

Not actual size

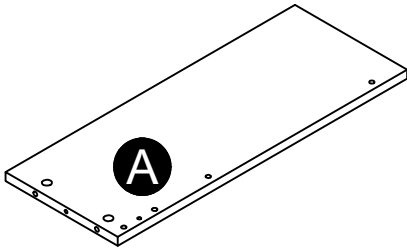

Left Panel
39016015010

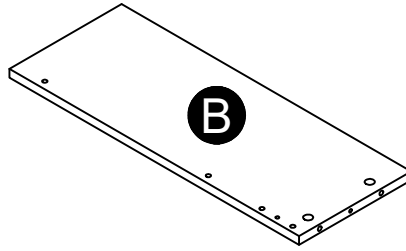

Right Panel
39016015020

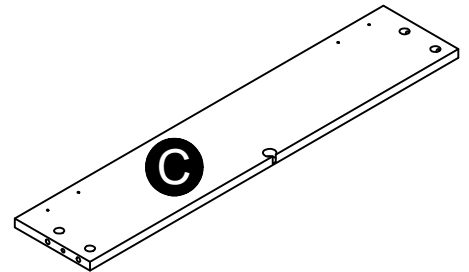

Upper Front
39016015030

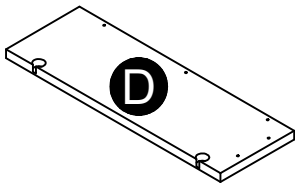

Left Front
39016015040

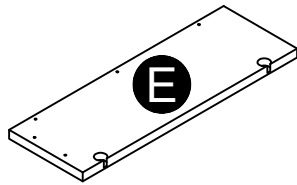

Right Front
39016015050

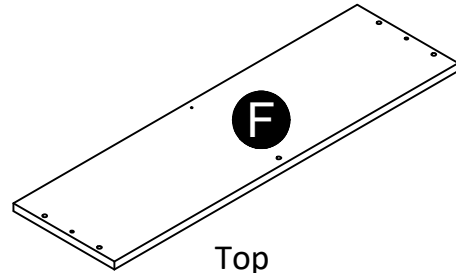

Top
39016015060

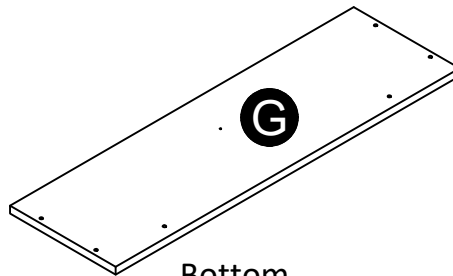

Bottom
39016015070

Board Identification

Not actual size

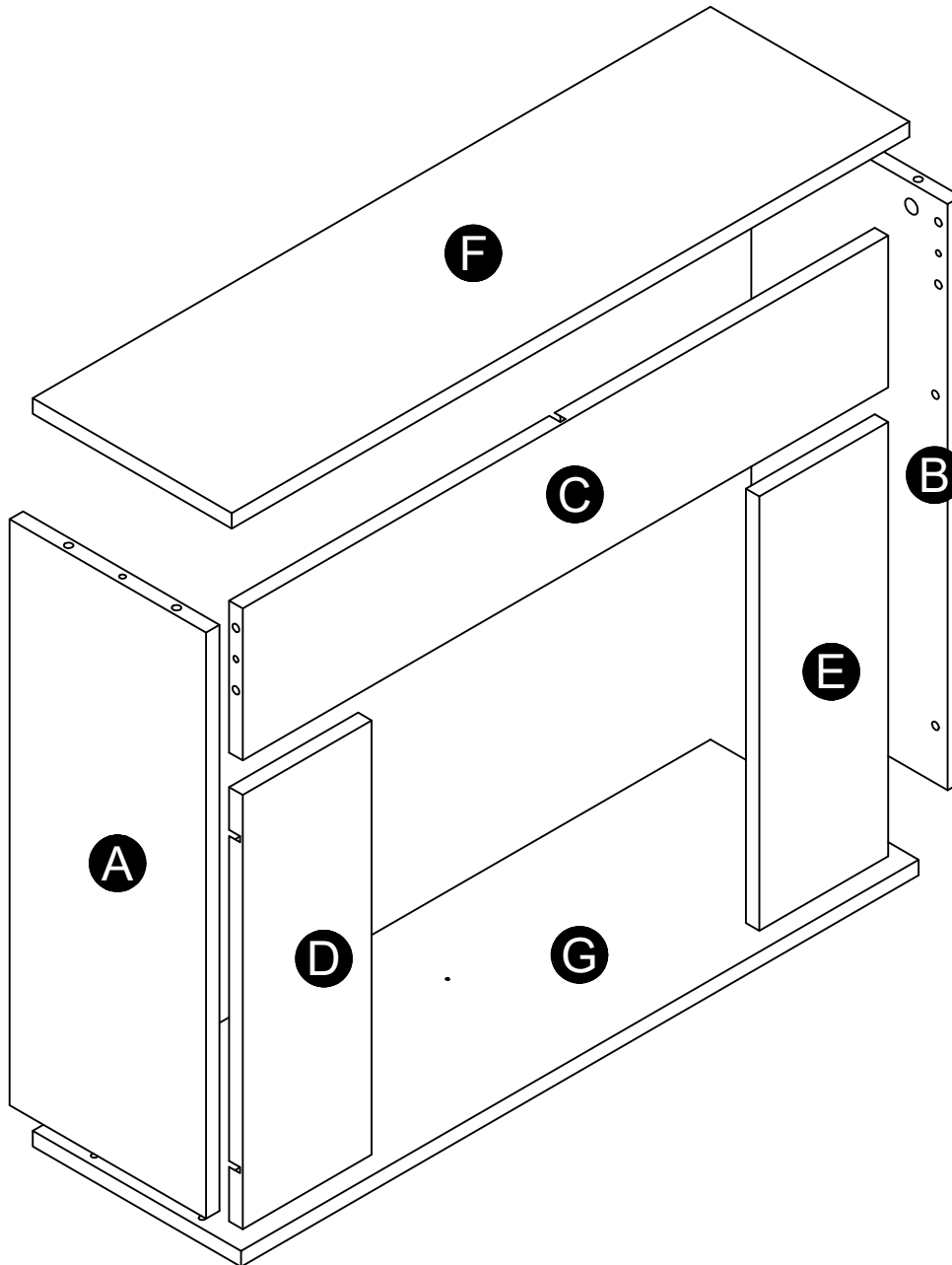

Part List

Actual Size

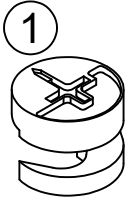

(x8)
#A22700
cam lock

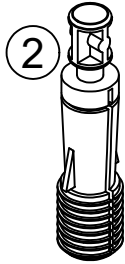

(x8)
#A22710
cam bolt

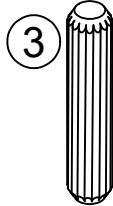

(x4)
#A21670
wood dowel

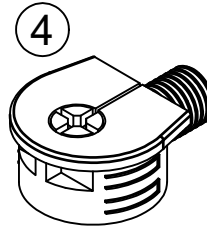

(x5)
#A22760
quickloc

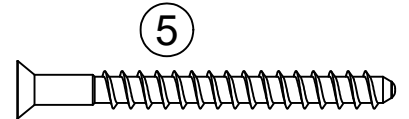

(x6)
#A23030
confirmat screw



(x15)
#A12120
7/16" screw



(x12)
#A14220
1/2" screw

Not Actual Size

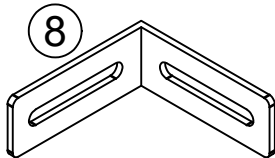

(x1)
#A53655
bracket

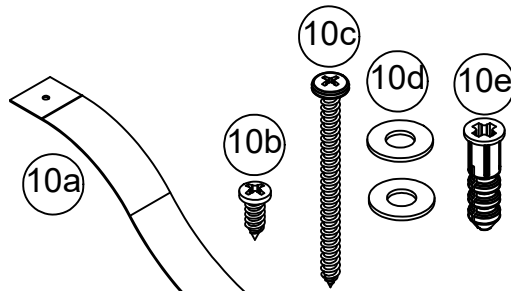

(x1)
#A84000
safety strap kit

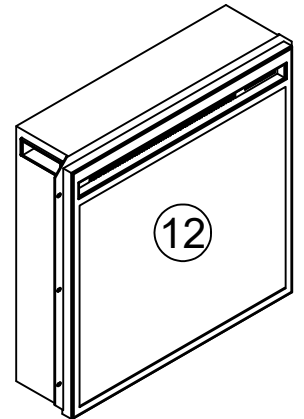

(x1)
#A95020
fireplace insert

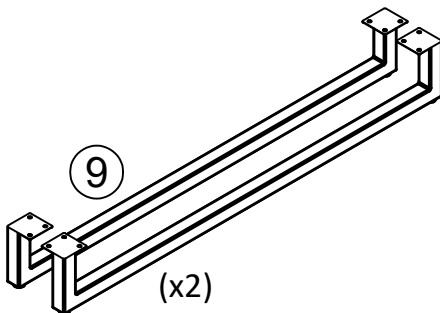

(x2)
#A95490
metal leg

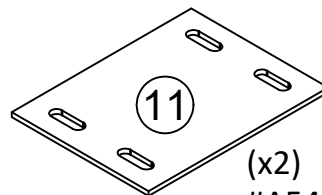

(x2)
#A54270
metal plate

STEP 1

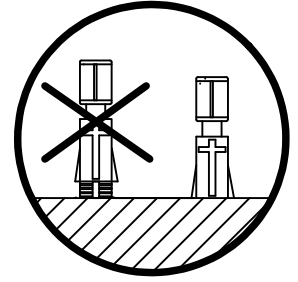
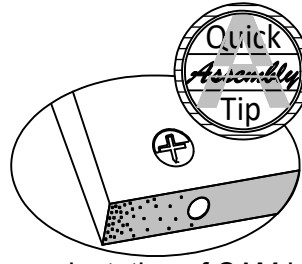
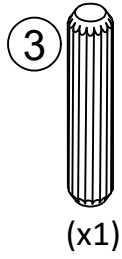
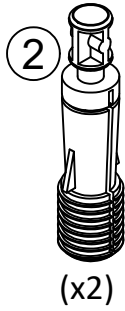
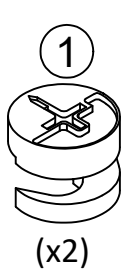

Proper orientation of CAM LOCK

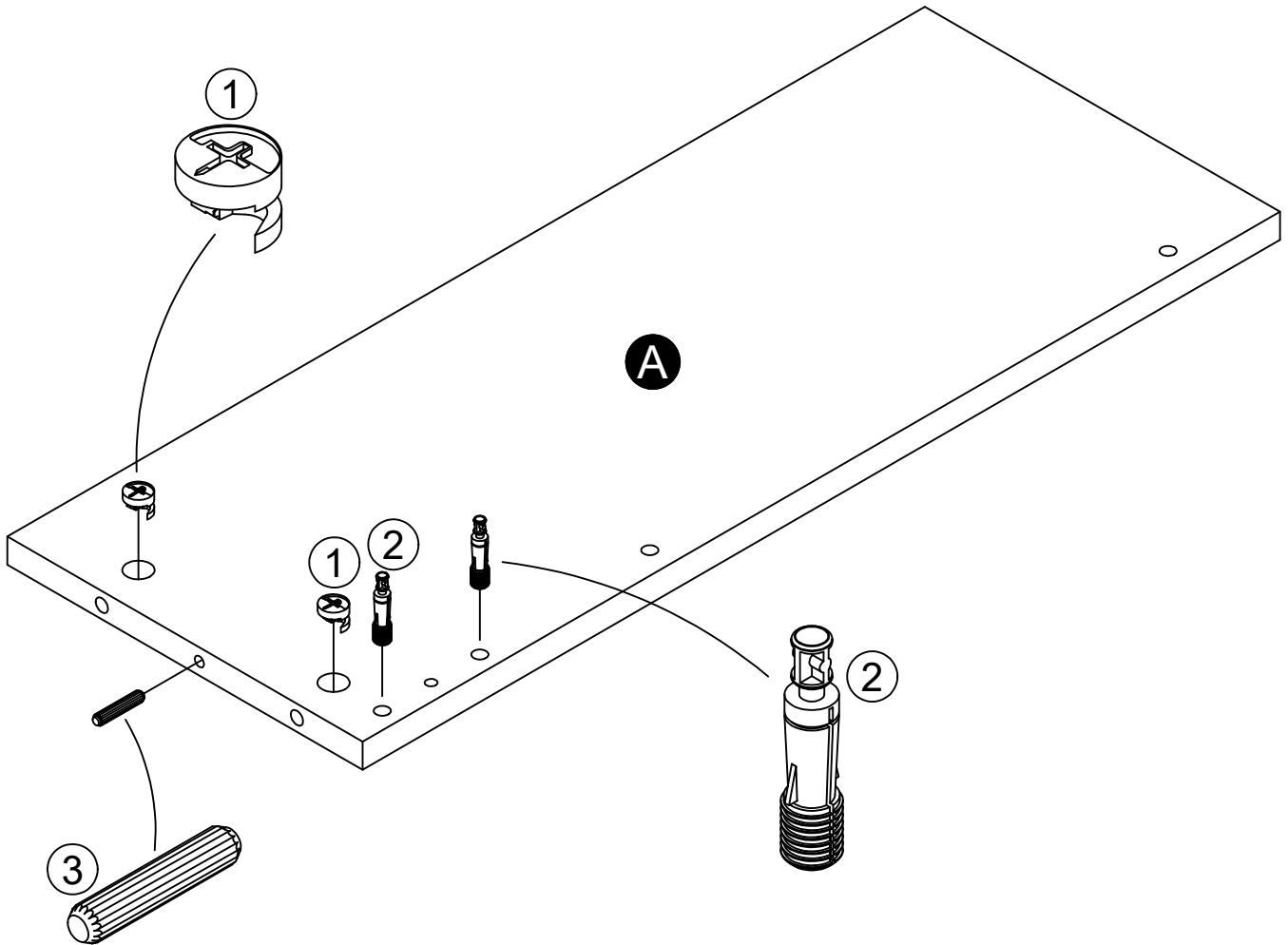

STEP 2

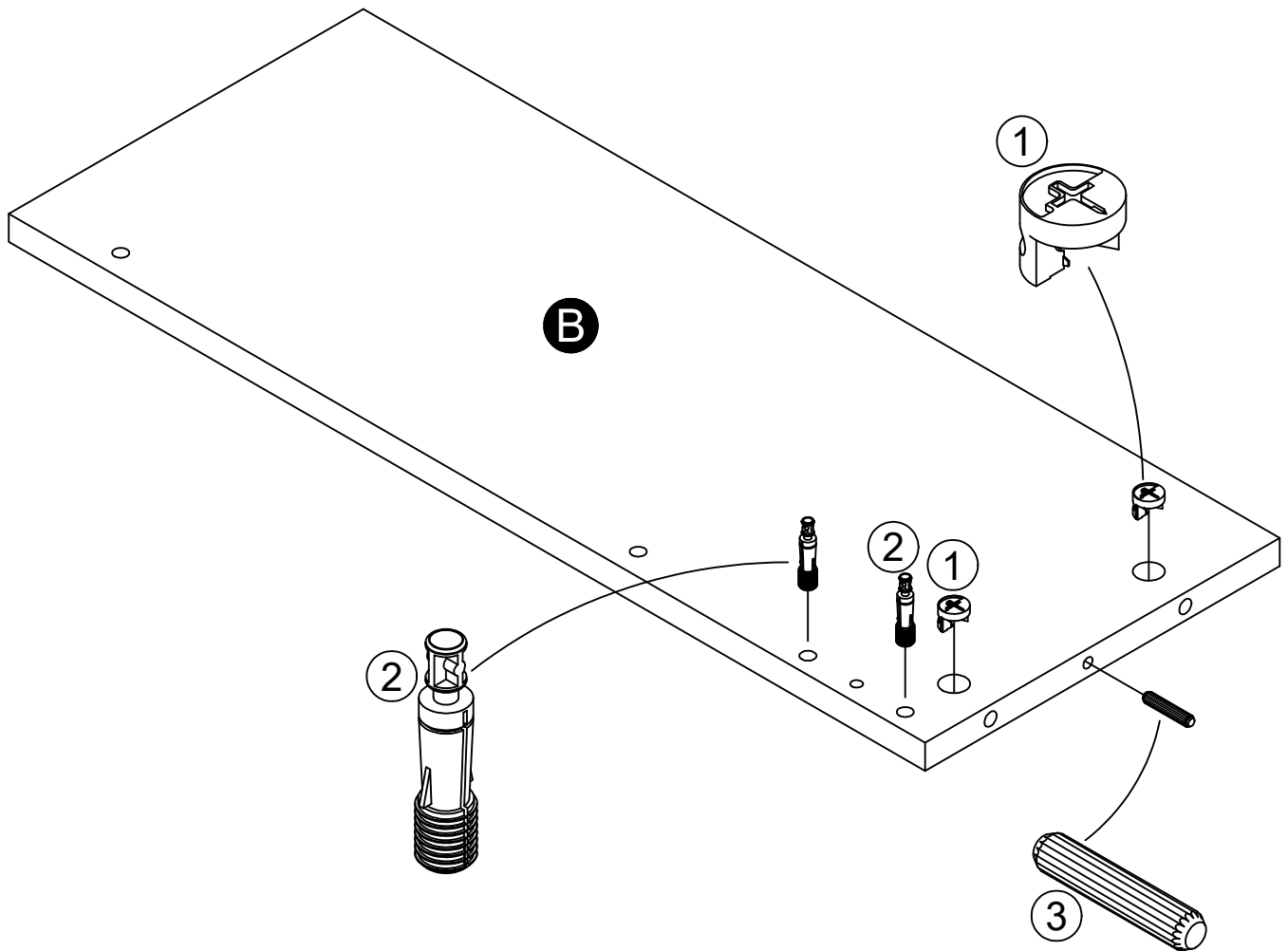
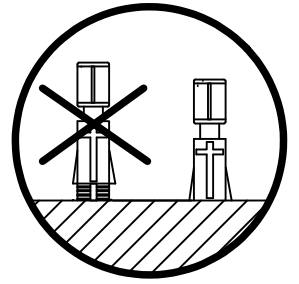
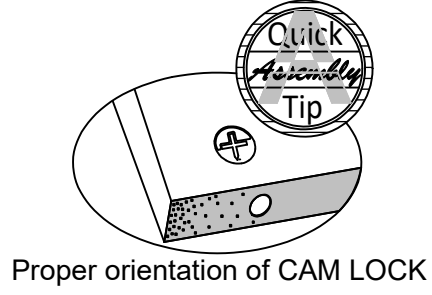
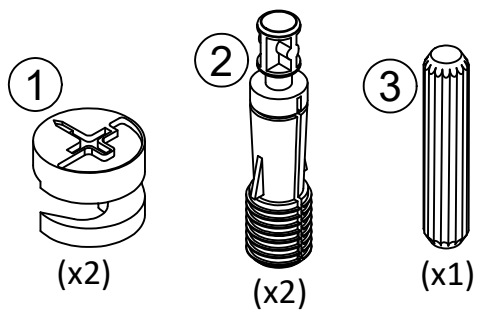

STEP 3

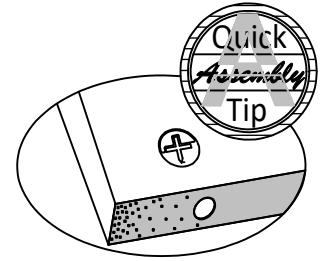
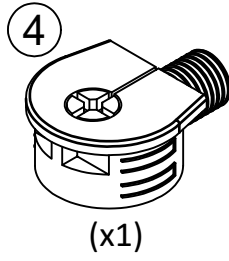
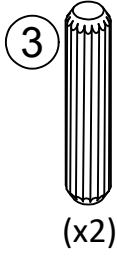
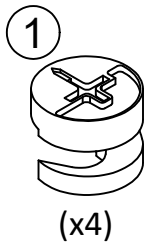

Proper orientation of CAM LOCK

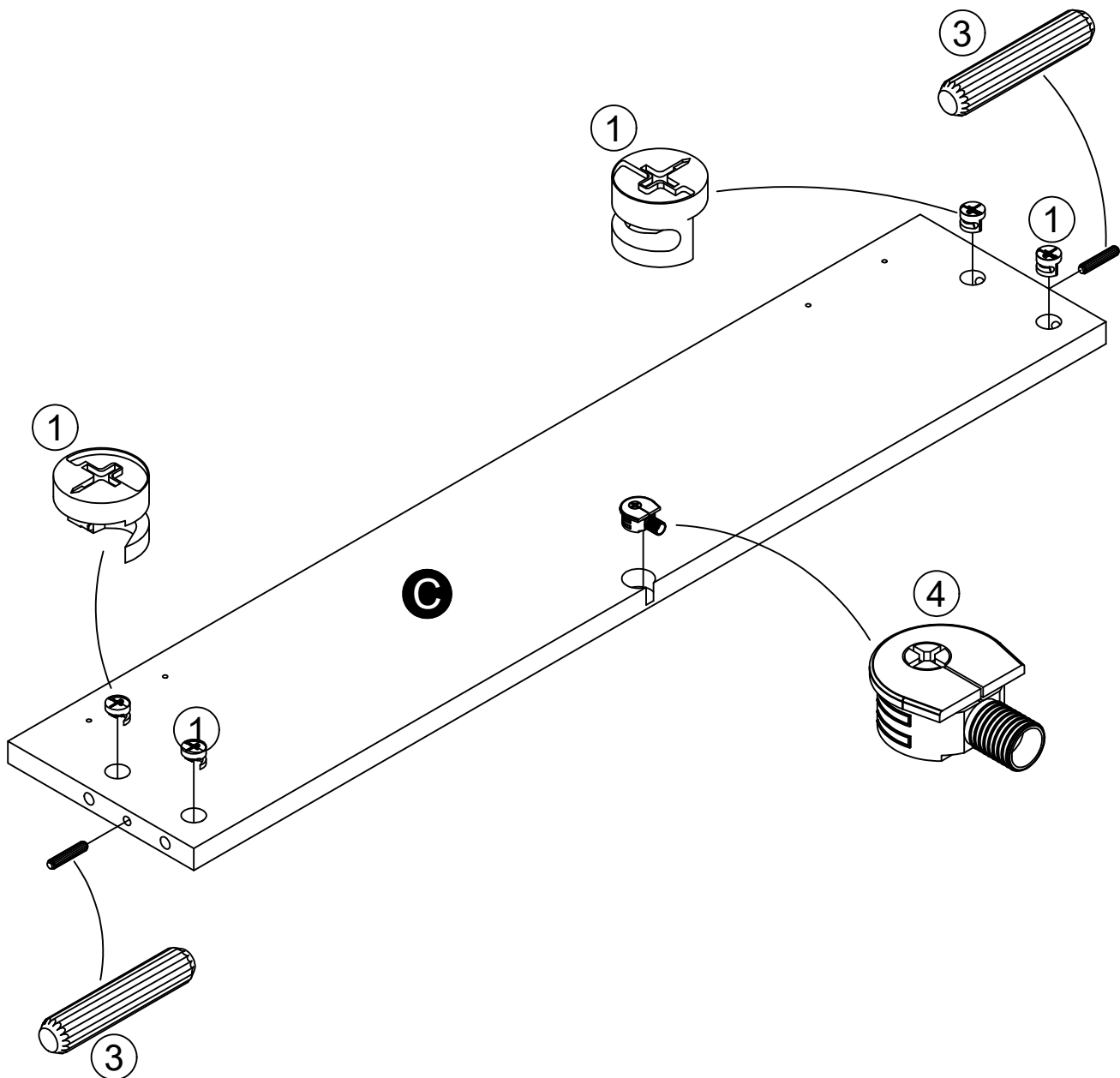

STEP 4

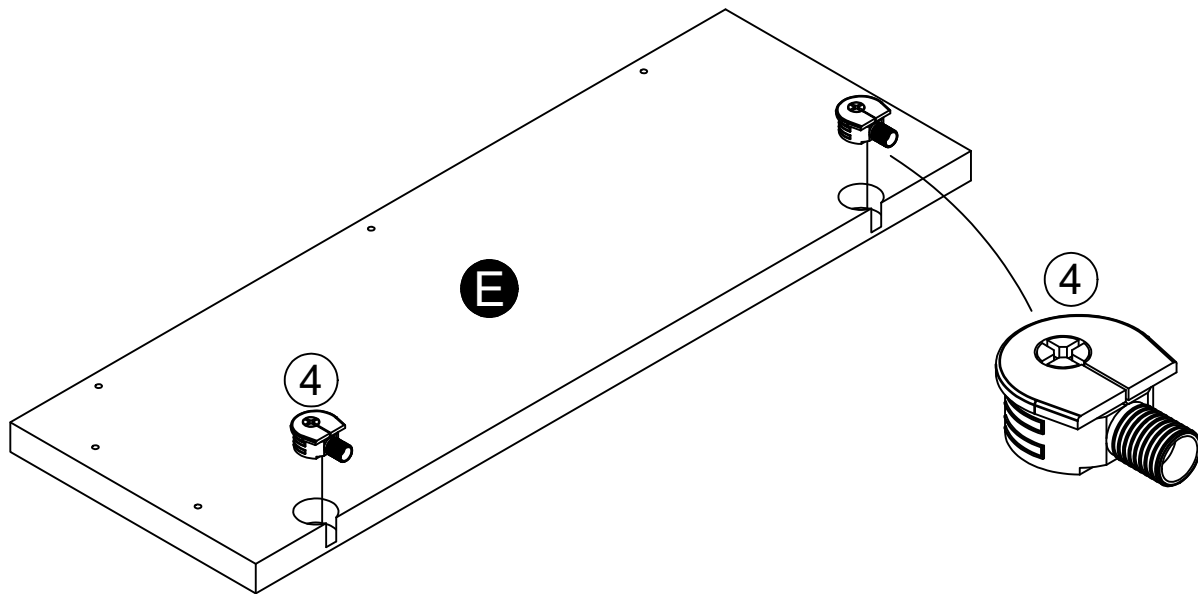
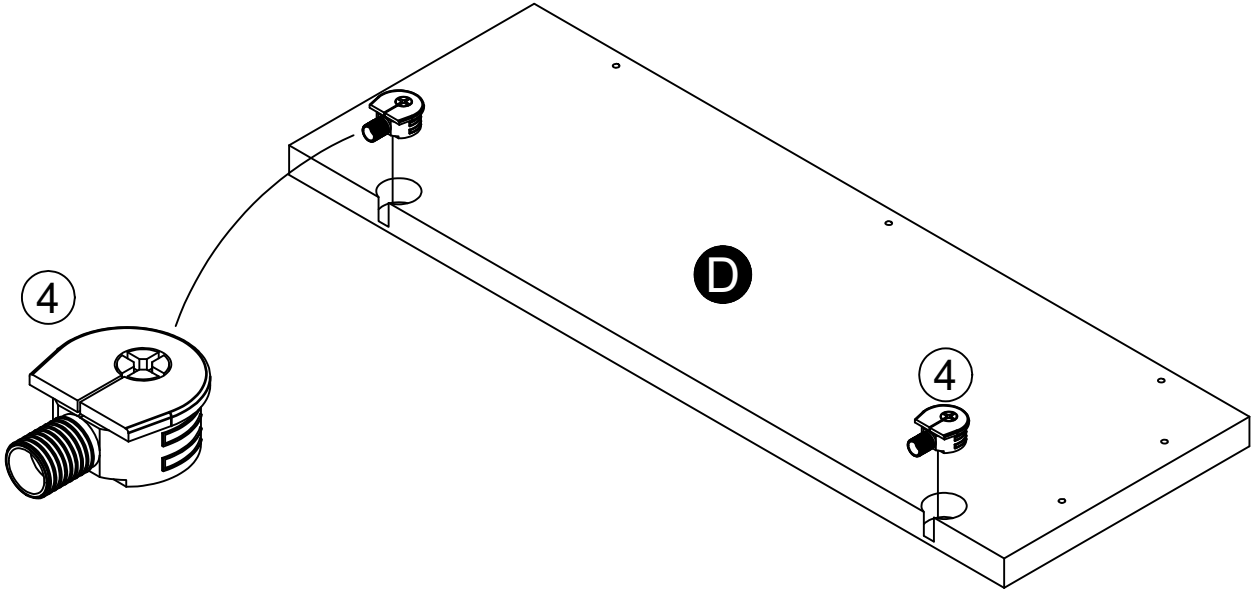
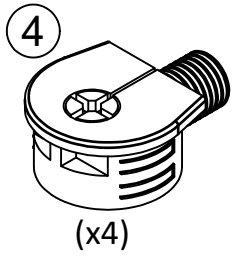

STEP 5

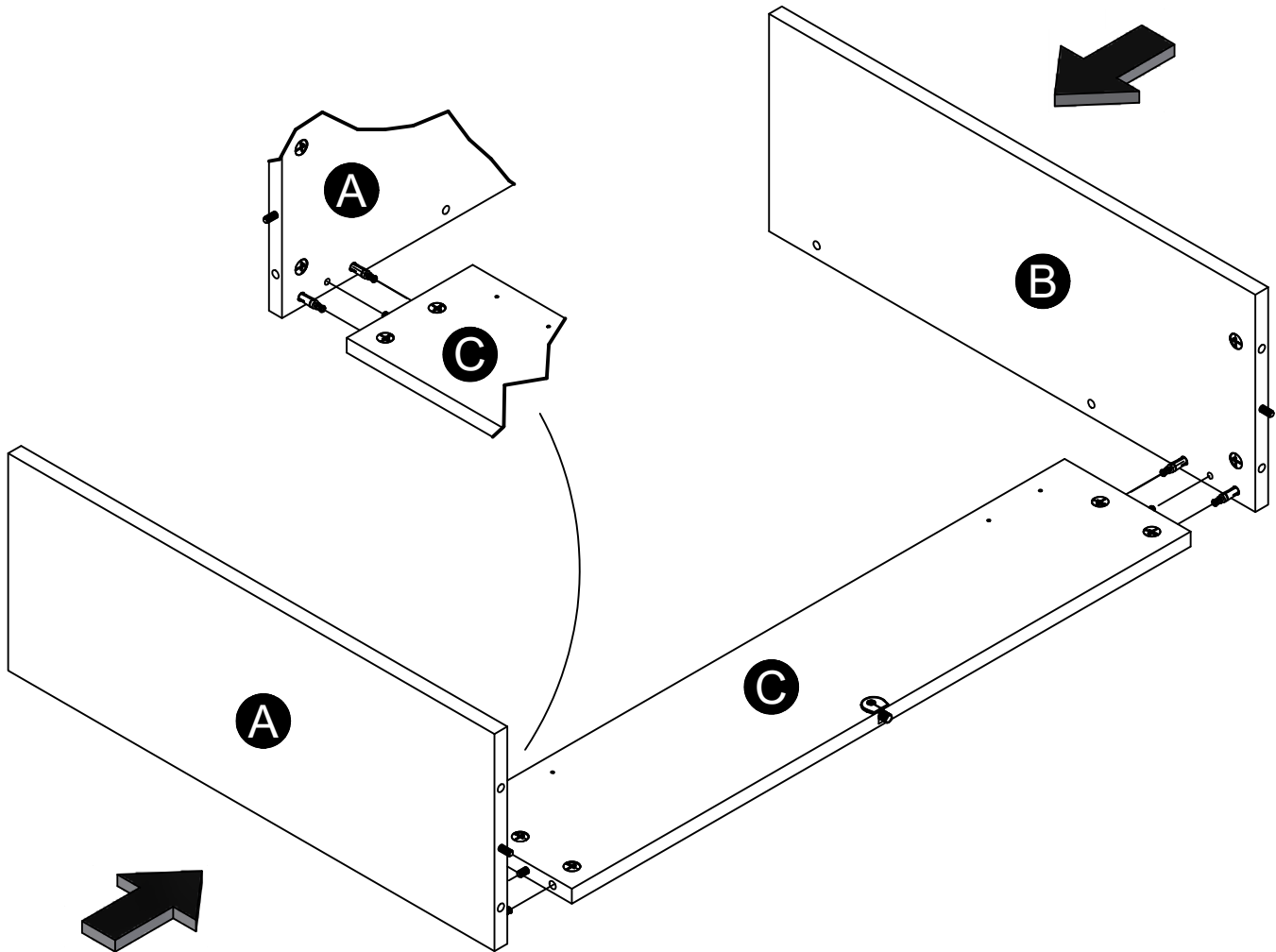
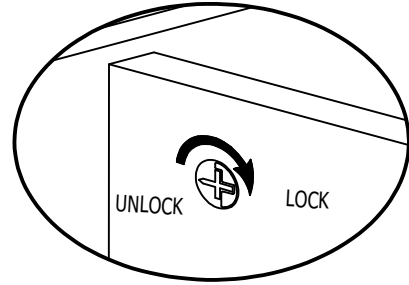
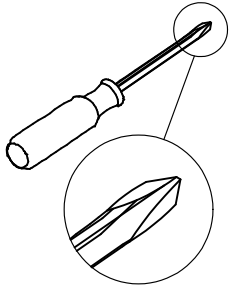

STEP 6

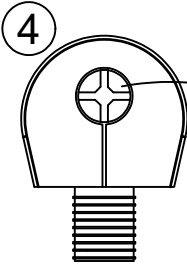
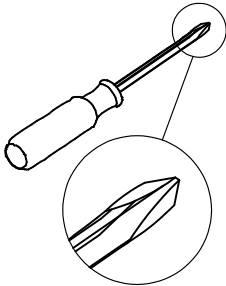

Turn screw clockwise to clamp parts together

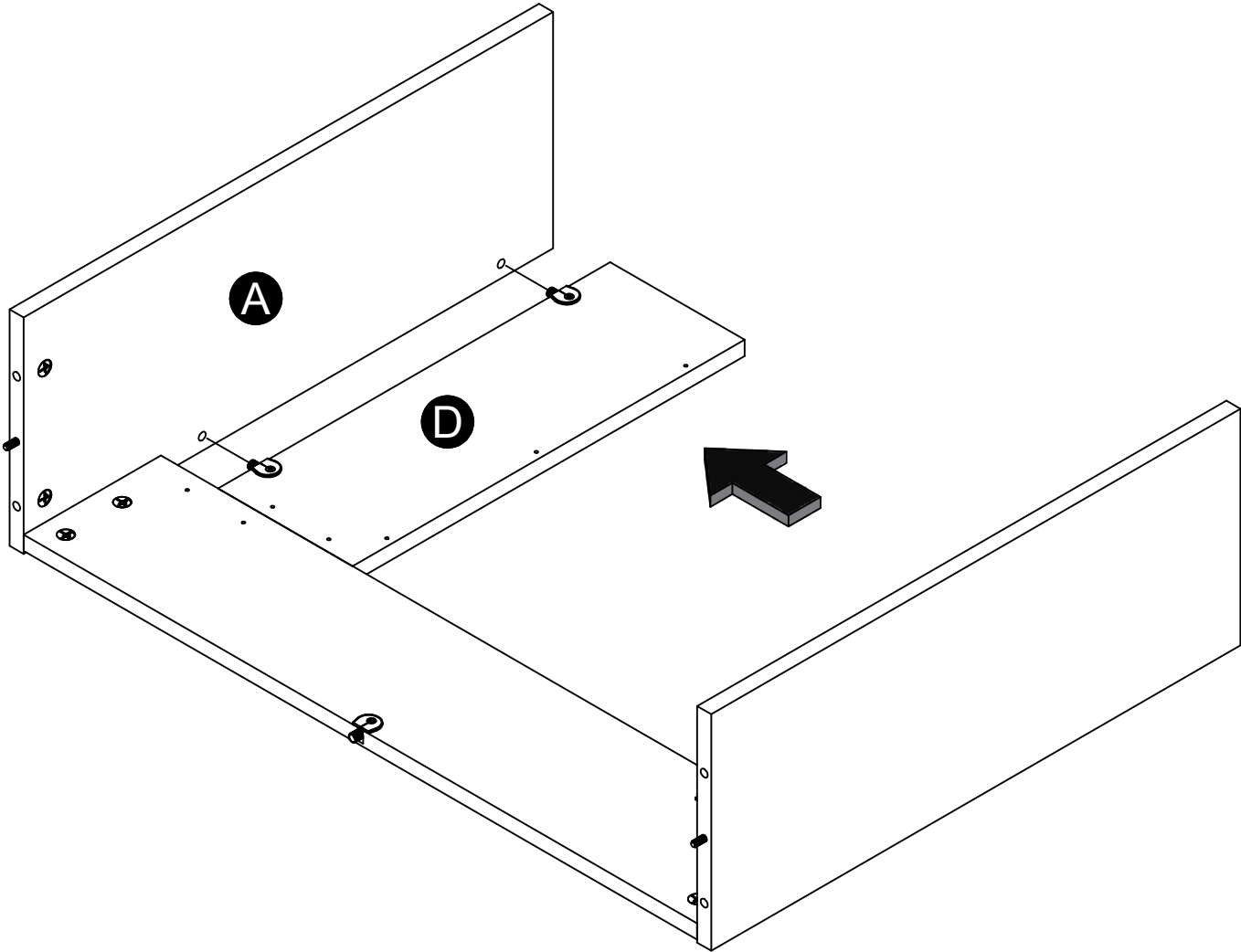

STEP 7

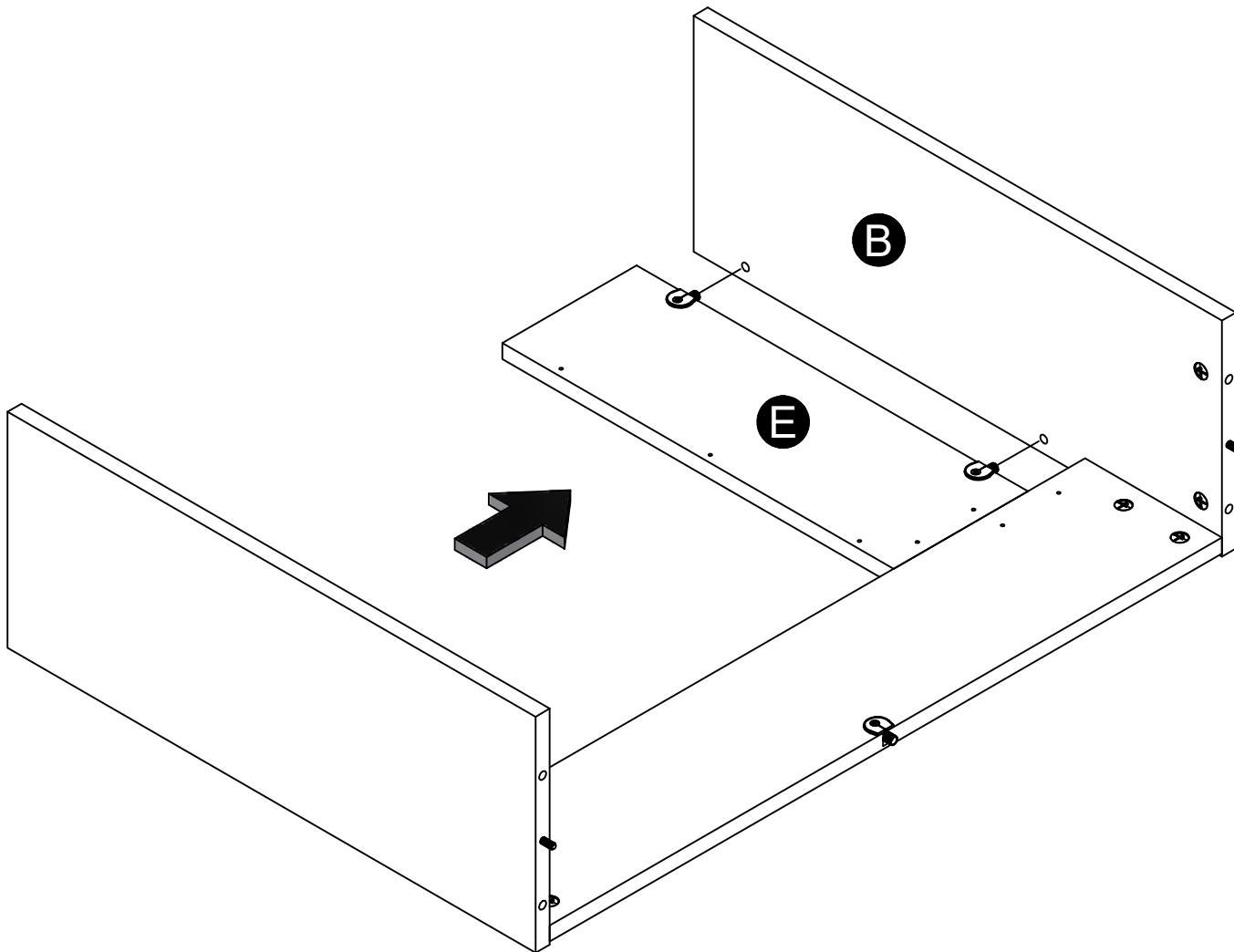
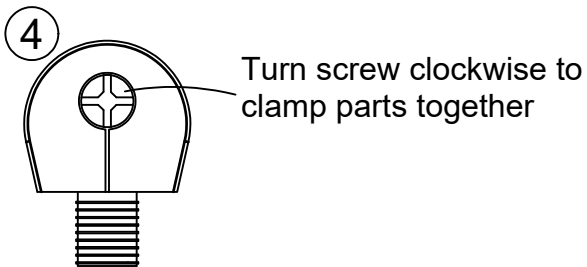
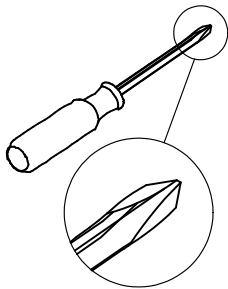

STEP 8

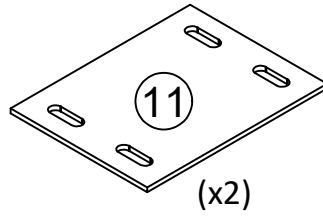
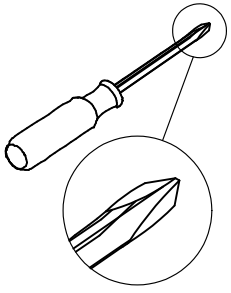

Note:

Be sure to use screw no. 6 for this step!
Screw no. 7 has a larger head and body.

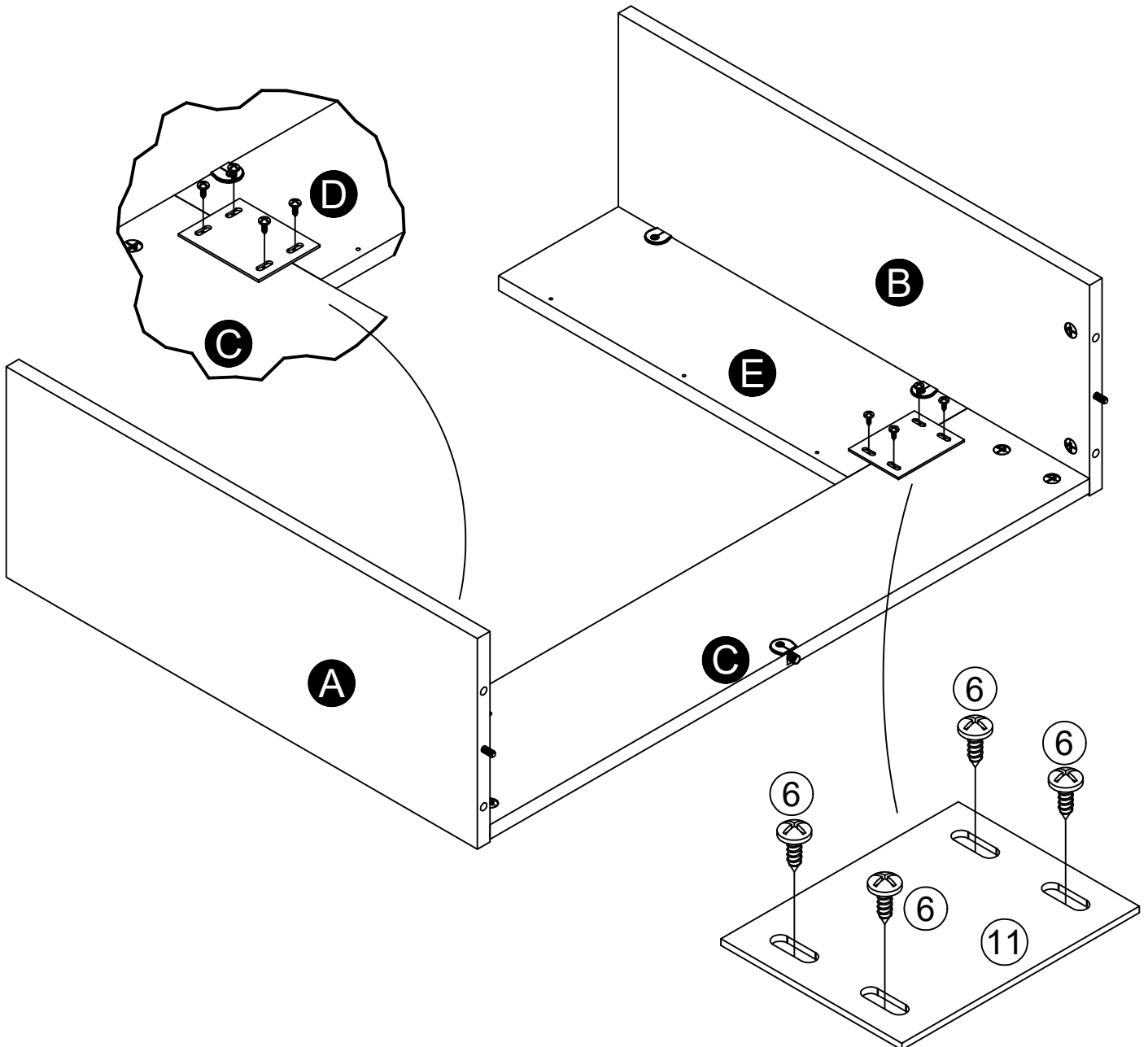

STEP 9

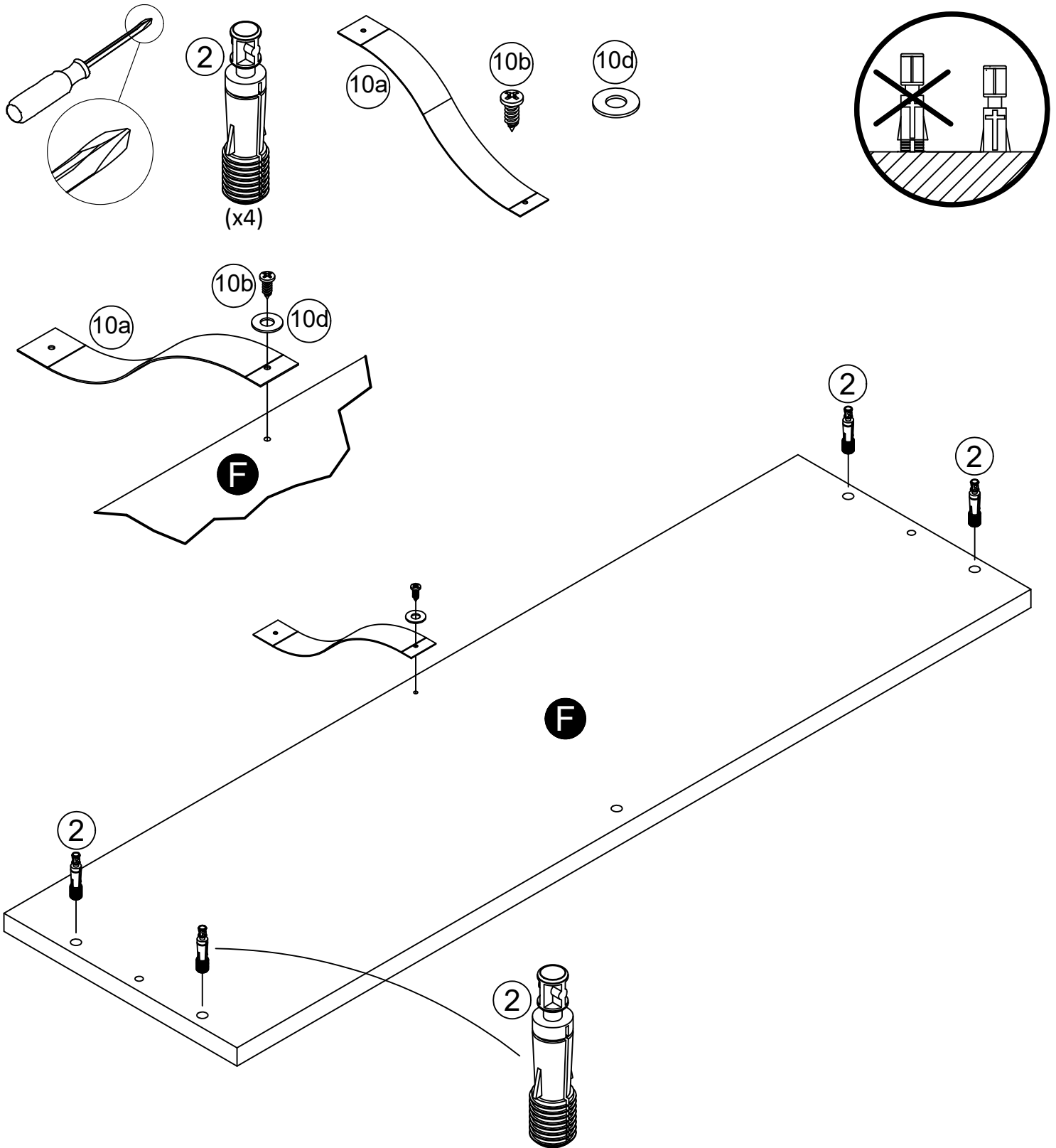

STEP 10

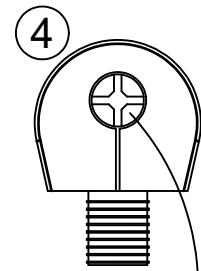
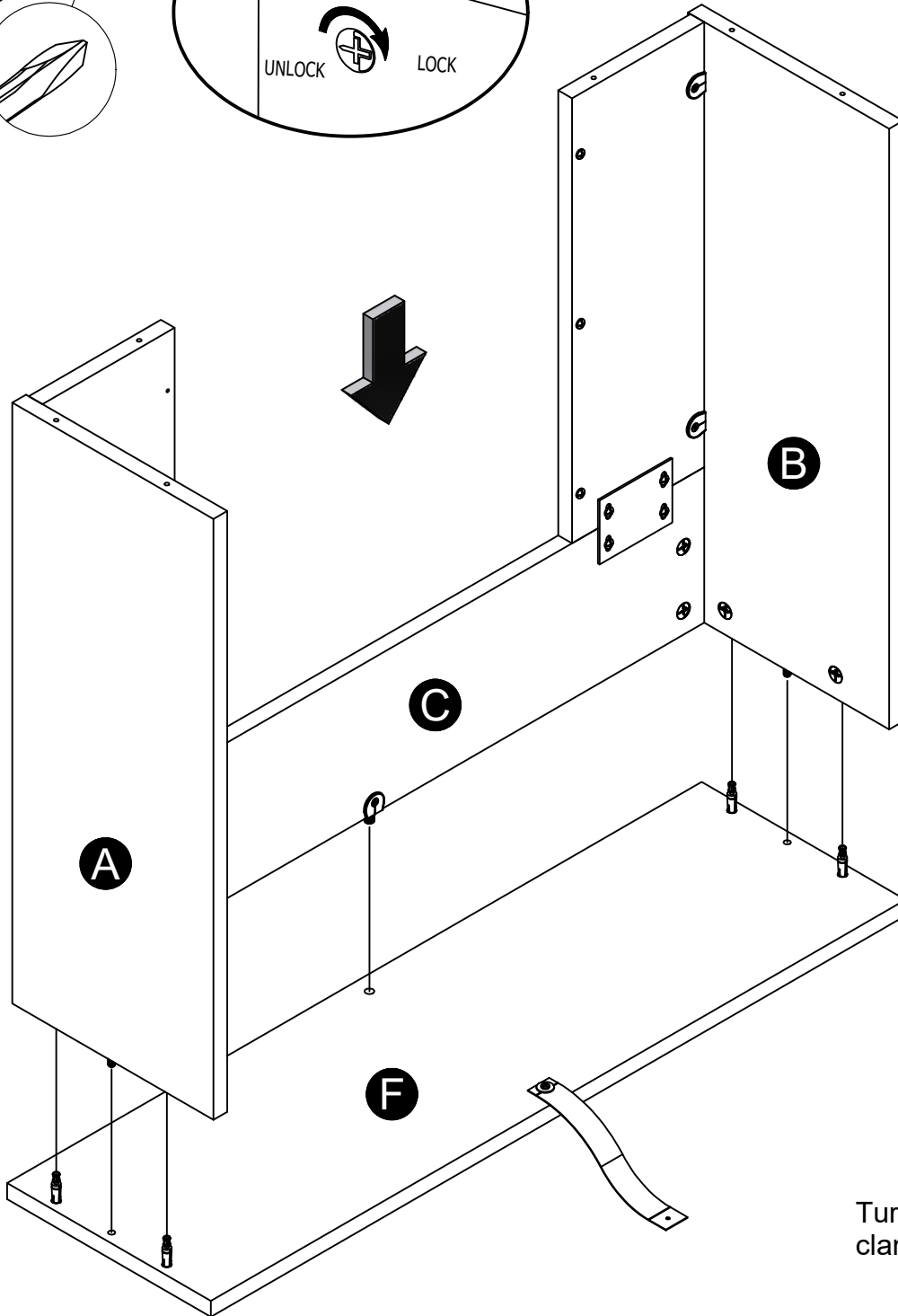
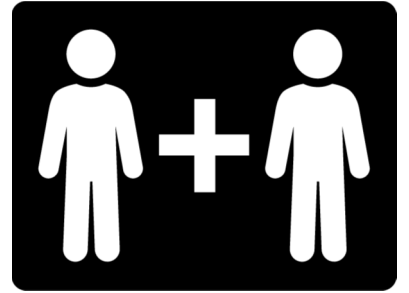
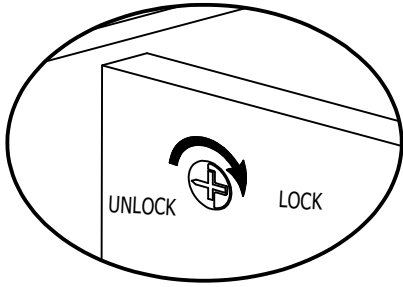
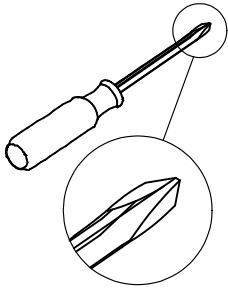

Turn screw clockwise to clamp parts together

STEP 11

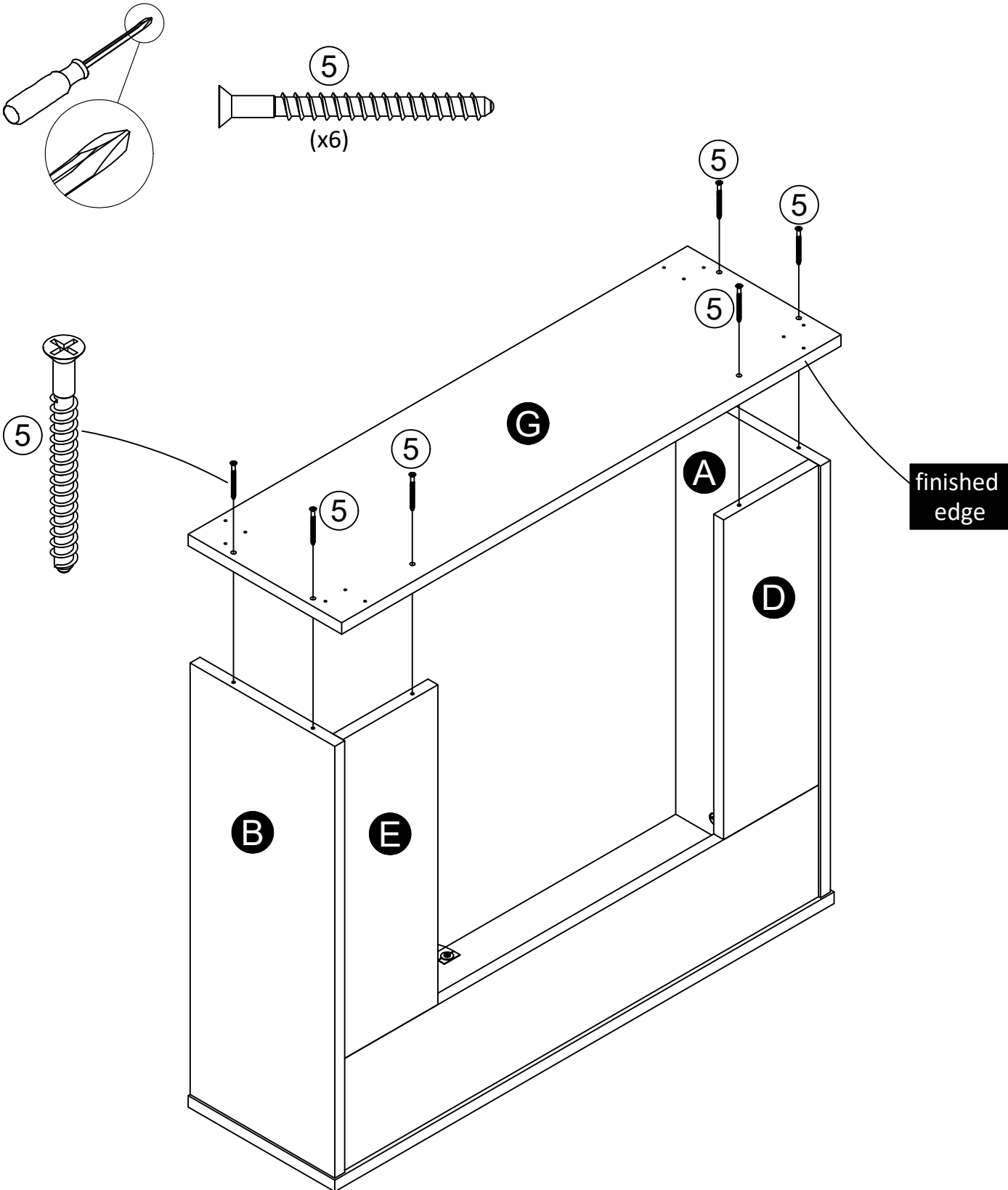

STEP 12

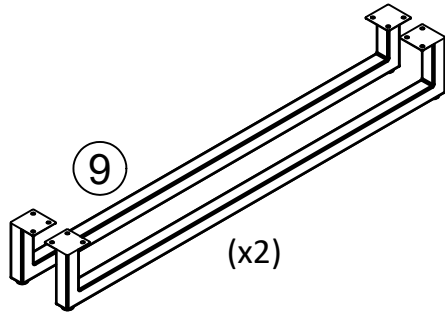
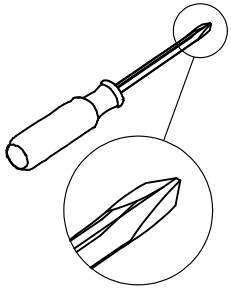

Note:
Be sure to use screw no. 7 for this step!
Screw no. 7 has a larger head and body.

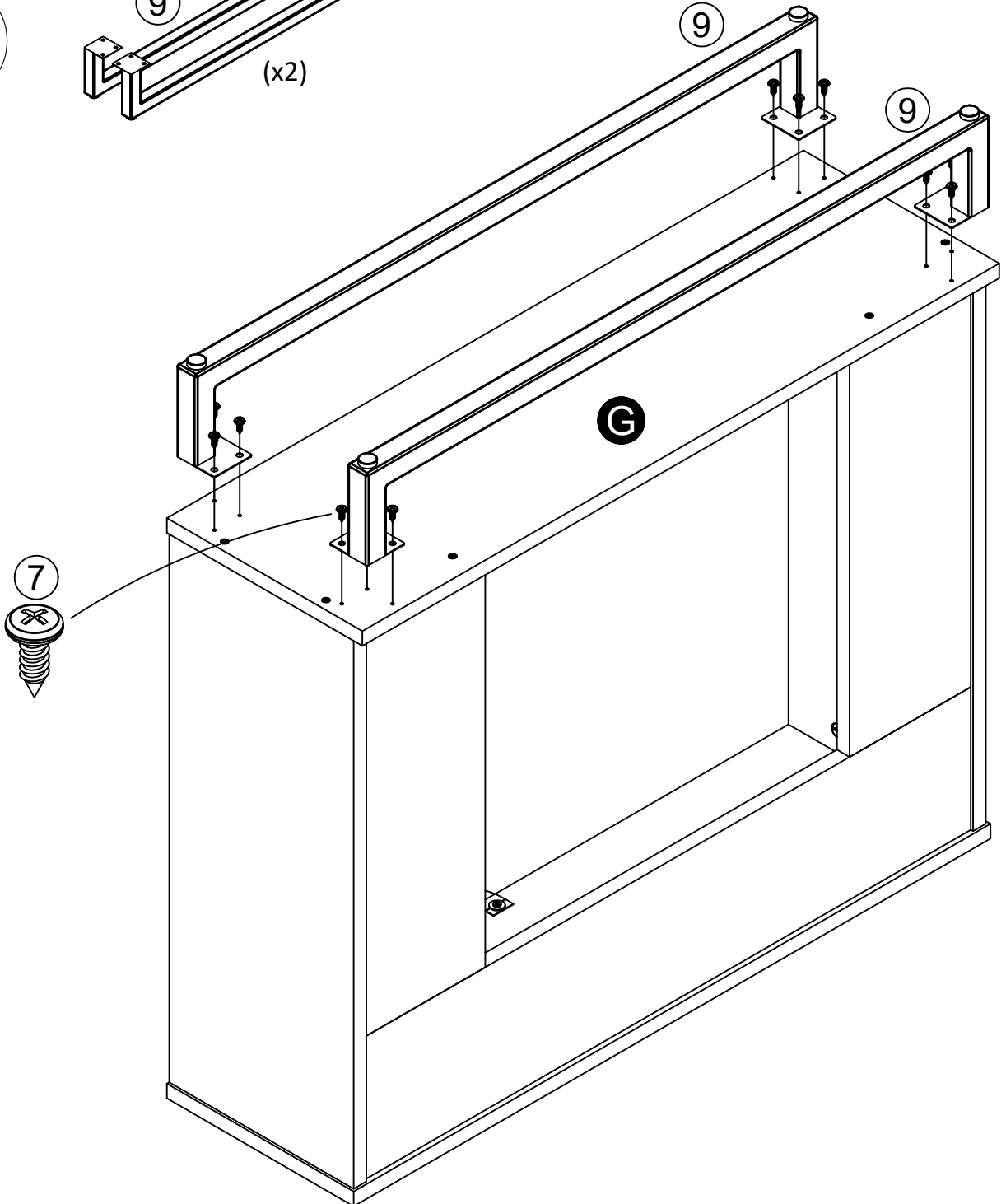
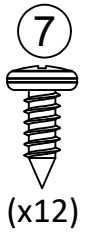

STEP 13

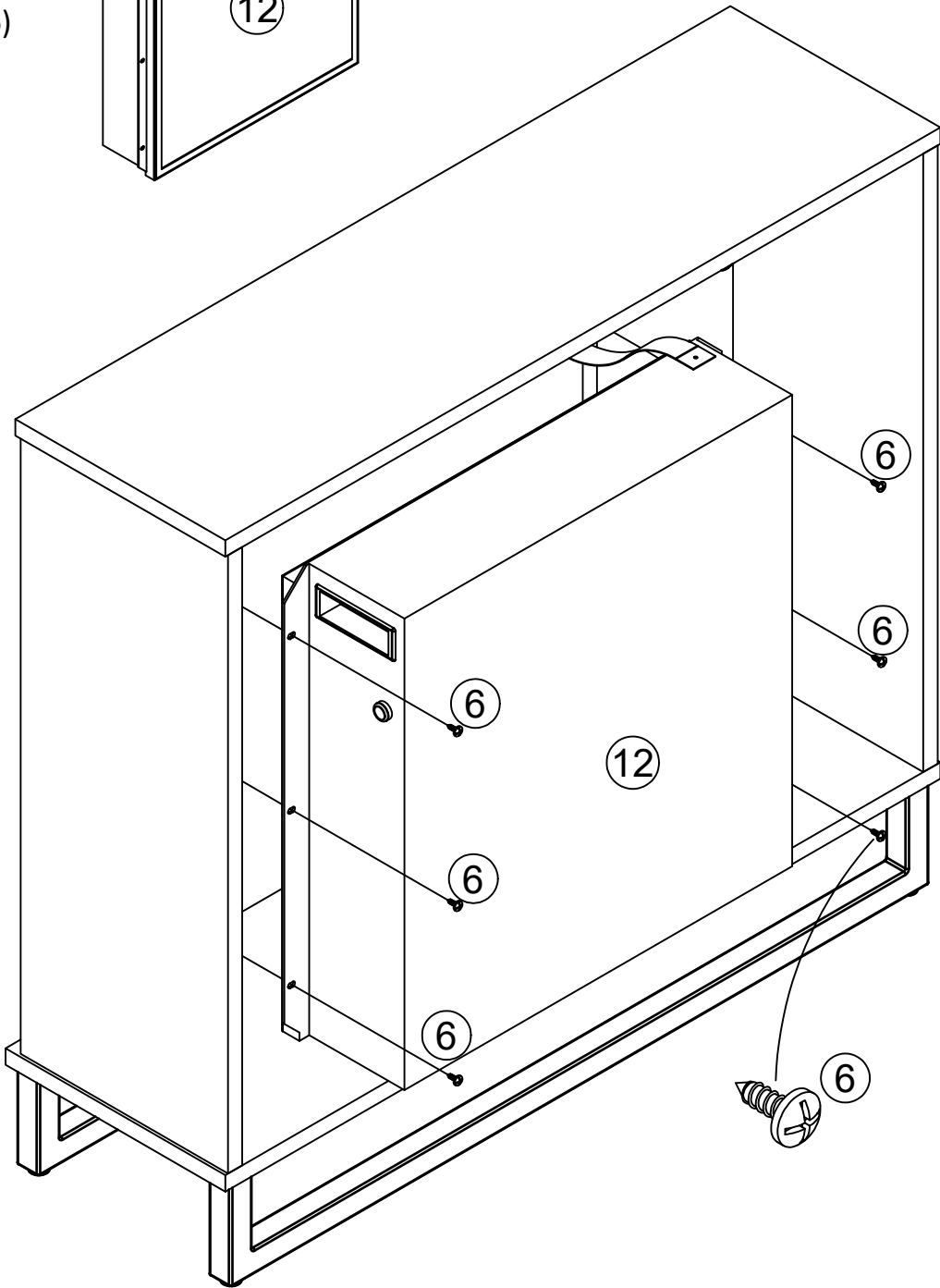
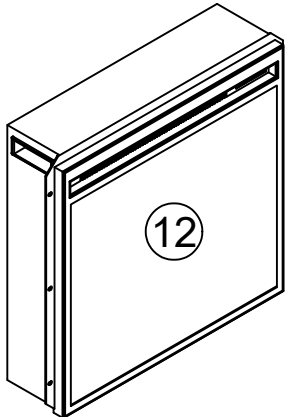
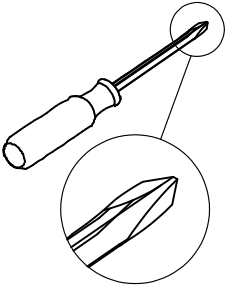

STEP 14

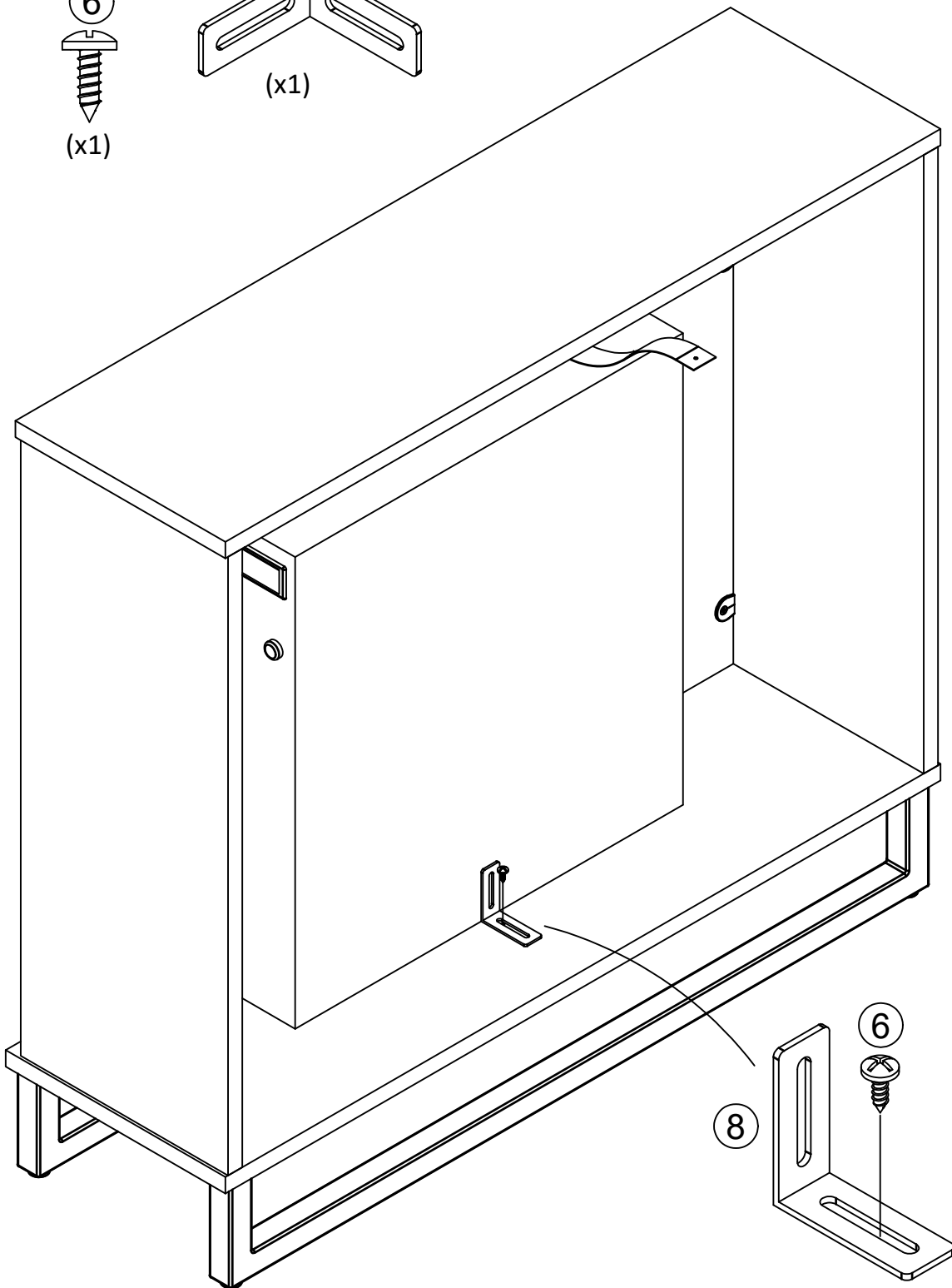
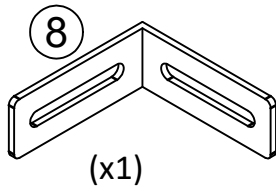
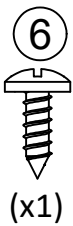
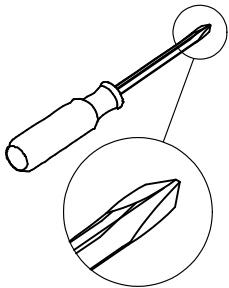

STEP 15

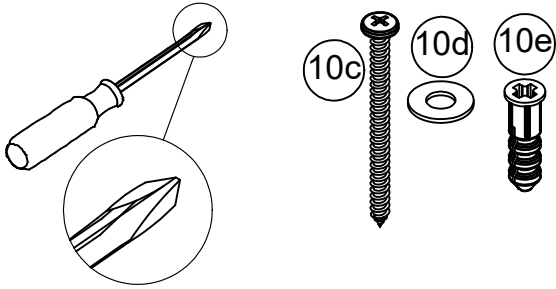

For Masonry, Concrete, or other wall materials:

Consult your local hardware store for appropriate anchors to securely attach the safety bracket.

IMPORTANT: THIS UNIT MUST BE SECURE TO THE WALL TO HELP PREVENT TIPOVER. FOLLOW THESE INSTRUCTIONS TO INSTALL THE ANTI-TIPPING SAFETY BRACKET PROVIDED WITH THIS PRODUCT.

WARNING

Serious or fatal crushing injuries can occur from furniture tipover.

To prevent tipover:

- * Install tipover restraint provided
- * Place heaviest items in the lowest drawers
- * Unless specifically designed to accommodate, do not set TVs or other heavy objects on the top of this product
- * Never allow children to climb or hang on drawers, door, or shelves
- * Never open more than one drawer at a time

Use of tipover restraints may only reduce, but not eliminate the risk of tipover

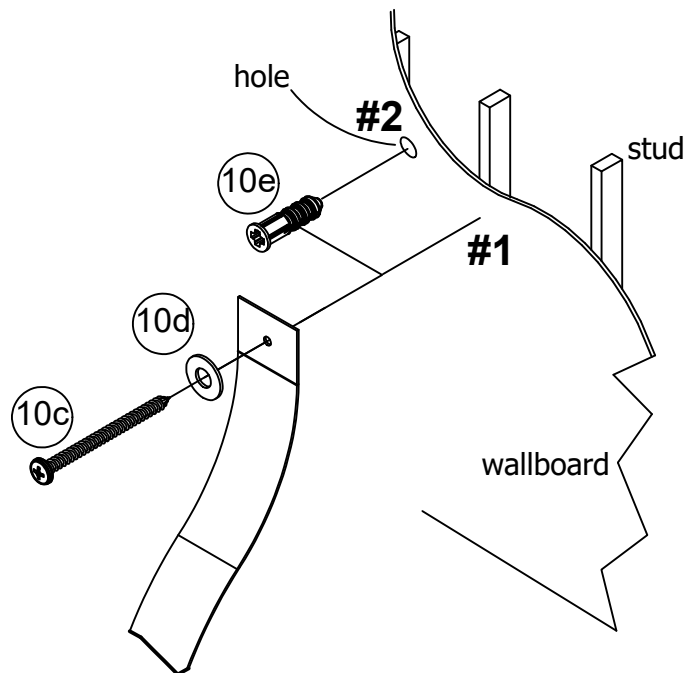

OPTION 1: Attachment into a wall stud (preferred method)

Using a stud finder, locate a stud in the wall. Place your unit against the wall, with the safety bracket aligned in this location. To make driving the screw easier, you can drill a 1/8" diameter pilot hole (3mm) through the safety bracket into the stud. Drive the screw through the safety bracket into the wall stud.

OPTION 2: Attachment into drywall

Locate your unit where desired against a wall and mark the wall through the safety bracket, then move your unit aside. Drill a 3/16" diameter hole (5mm) into the wallboard. Tap the wall anchor into the hole until it is flush. Move your unit into location and fasten the wall bracket to the wall anchor with the screw.

Maximum Loads

This unit has been designed to support the maximum loads shown. Exceeding these load limits could cause sagging, instability, product collapse, and/or serious injury.

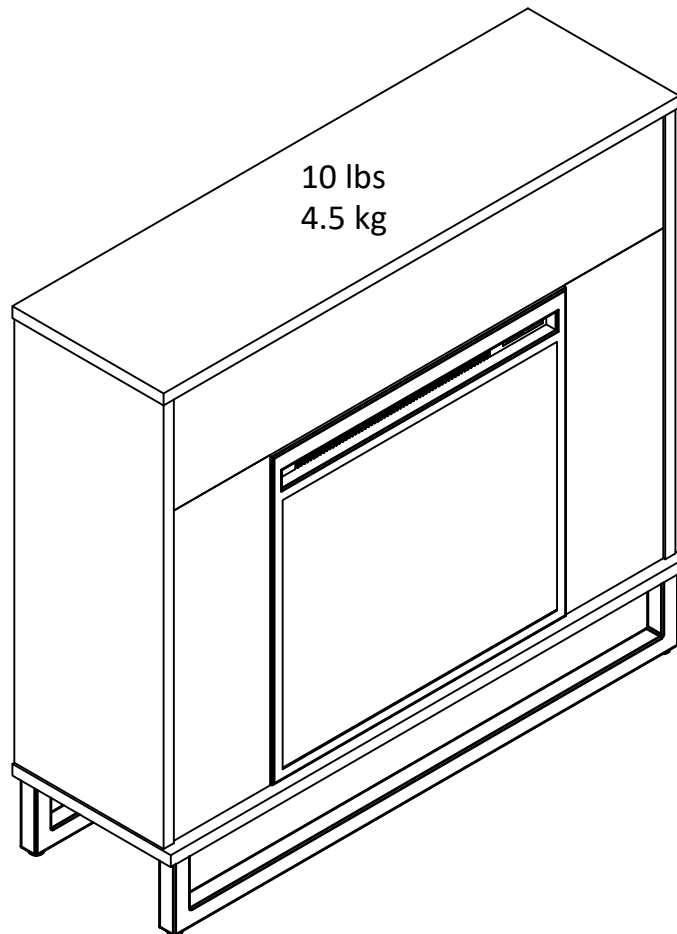

Warning: Risk of injury to persons - do not place a television on this furniture. This furniture is not approved for use with a television.

Certificate of Conformity

1. This certificate applies to the Dorel Home Furnishings, Inc. product identified by this instruction manual.
2. This certificate applies to compliance of this product with the CPSC Ban on Lead-Containing Paint (16 CFR 1303).
3. This product is distributed by: Dorel Home Furnishings, Inc.
410 East First Street South
Wright City, MO 63390
636-745-3351
4. Site of Manufacture: Tiffin OH
5. See front page of instruction manual for date of manufacture.

Register your product to receive the following:



- * New trend details - sneak peek on what's new
- * Surveys - have a voice within our community
- * Exclusive deals and discount codes
- * Quick and easy replacement part service

To register your product, visit ameriwoodhome.com

5 Star Rating



Visit your local retailer's website, rate your purchased product and leave us some feedback!

We would like to extend a big "Thank You" to all of our customers for taking the time to assemble this Ameriwood Home product, and to give us your valuable feedback.

*Thank
You!*

Cubierta Delantera

Este libro de instrucciones contiene información **IMPORTANTE** de seguridad. Por favor lea y manténgalo para referencia en el futuro.

No Regrese este producto! Comuníquese con nuestro amigoso equipo de servicio al cliente para obtener ayuda.

Llámenos al: 1-800-489-3351 (Gratis) Lunes - Viernes 9am - 5pm CST

Visitar: www.ameriwoodhome.com

PRECAUCION

Este mueble puede volcarse y causar graves heridas y/o muerte.

Anclar el mueble a un poste de madera en la pared (si esto se requiere).

No Permita que los niños monten el mueble.

Mantenga los artículos más pesados en los cajones de abajo.

Consejos Útiles (página 2)

- Abra su artículo en el área donde usted planea utilizarlo para evitar levantar y moverlo menos
- Identificar, ordenar y contar las piezas antes de intentar ensamblar
- Las clavijas de compresión se golpean con un martillo
- Las diapositivas están marcadas con una R (derecha) y L (izquierda) para la colocación correcta
- Asegúrese de que siempre este el punto localizado en la parte superior de bloqueador de leva este volteado hacia borde exterior
- Utilizar todos los clavos para el panel de atrás y distribuirlos por igual
- El panel de atrás debe utilizarse para asegurarse de que la unidad quede fija y firme
- No use químicas fuertes ni limpiadores abrasivos en este artículo
- Nunca empuje, tire ni arrastre los muebles

Antes de Que Empieces (página 3)

- Lea cuidadosamente cada paso y siga el orden correcto
- Separar y contar todas sus piezas y hardware
- Dése suficiente espacio para el proceso de ensamble
- Tenga las siguientes herramientas: destornillador de cabeza plana, #2 cabeza Phillips
Destornillador y martillo
- Precaución: Si usa un taladro electrónico o un destornillador eléctrico para atornillar, por favor asegúrese que deje de atornillar cuando el tornillo este apretado. Fallar hacer esto puede causar barrer el tornillo.

Sistema de fijar el bloqueo de leva (página 3)

Este sistema de fijar el bloqueo de leva sera usado en todo el proceso ensamble.

Página 13, 14, 17

Gire el tornillo en el sentido de las agujas del reloj para sujetar las piezas.

Página 15

Nota:

¡Asegúrese de utilizar el tornillo nº 6 para este paso!

El tornillo nº 7 tiene la cabeza y el cuerpo más grandes.

Página 19

Nota:

¡Asegúrese de utilizar el tornillo nº 7 para este paso!

El tornillo nº 7 tiene la cabeza y el cuerpo más grandes.

Página 22

Para mampostería, hormigón u otros materiales de pared:

Consulte en su ferretería de confianza los anclajes apropiados para fijar el soporte de seguridad de forma segura.

IMPORTANTE: ESTA UNIDAD DEBE ESTAR FIJADA A LA PARED PARA EVITAR QUE SE VUELQUE. SIGA ESTAS INSTRUCCIONES PARA INSTALAR EL SOPORTE DE SEGURIDAD ANTIVUELCO SUMINISTRADO CON ESTE PRODUCTO.

ADVERTENCIA

El vuelco del mueble puede provocar lesiones graves o mortales por aplastamiento.

Para evitar el vuelco:

- * Instale el soporte antivuelco suministrado
- * Coloque los artículos más pesados en los cajones inferiores
- * A menos que esté diseñado específicamente para ello, no coloque televisores u otros objetos pesados en la parte superior de este producto
- * No permita nunca que los niños trepen o se cuelguen de los cajones, puertas o estantes
- * No abra nunca más de un cajón a la vez

El uso de dispositivos de sujeción para el vuelco solo puede reducir, pero no eliminar, el riesgo de vuelco

OPCIÓN 1: Fijación en un montante de la pared (método preferido)

Con un localizador de montantes, localice un montante en la pared. Coloque su unidad contra la pared, con el soporte de seguridad alineado en esta ubicación. Para facilitar la colocación del tornillo, puede perforar un agujero piloto de 1/8" de diámetro (3 mm) a través del soporte de seguridad en el montante. Introduzca el tornillo a través del soporte de seguridad en el montante de la pared.

OPCIÓN 2: Fijación en una pared de yeso laminado

Ubique su unidad en el lugar deseado contra una pared y marque la pared a través del soporte de seguridad, luego mueva su unidad a un lado. Perfore un agujero de 3/16" de diámetro (5 mm) en la pared. Golpee el anclaje de pared en el agujero hasta que esté al ras. Mueva su unidad a su ubicación y fije el soporte de pared al anclaje de pared con el tornillo.

Página 23

CARGA MAXIMA

Esta unidad ha sido diseñada para soportar las cargas máximas indicadas. Exceder estos límites de carga podría causar hundimiento, inestabilidad, colapso del producto y/o lesiones graves.

Advertencia: Riesgo de lesiones personales - no coloque un televisor en este mueble. El mueble no está aprobado para su uso con un televisor.

Página 24

Registre su producto para recibir lo siguiente:

- * Detalles de nuevas tendencias - Vistazo a lo nuevo
- * Encuestas - aloc su voz entre su comunidad
- * Códigos de ofertas y descuentos exclusivos
- * Fácil y rápido servicio de partes de remplace

Para registrar su producto, visite ameriwoodhome.com

Clasificación de 5 estrellas

Visite el sitio web de su tienda local, califique su comprado y denos sus comentarios!

Nos gustaría enviar un gran "Agradecimiento" a todos nuestros clientes por tomarse el tiempo de ensamblar este producto de Ameriwood Home, y por darnos sus valiosos comentarios.

Gracias

Couverture Avant

CE LIVRET D'INSTRUCTION CONTIENT DES INFORMATIONS **IMPORTANTES** SUR LA SÉCURITÉ. VEUILLEZ LIRE ET GARDER POUR UNE RÉFÉRENCE FUTURE

Ne retournez pas ce produit! Contactez notre équipe de service à la clientèle amicale d'abord pour obtenir de l'aide.

Appelez-nous: 1-800-489-3351 (sans frais) du Lundi au Vendredi de 9h à 17h Heure Centrale

Visitez: www.ameriwoodhome.com

ATTENTION

Le meuble peut basculer et causer des blessures graves ou la mort.

Ancrer le meuble à une planche murale dans le mur (si indiqué).

Ne laissez pas les enfants grimper sur le meuble.

Placez les articles lourds sur les étagères ou dans les tiroirs inférieurs.

Astuces Utiles (page 2)

-Ouvrez votre article dans la zone que vous prévoyez de le garder pour moins de levage lourd

-Identifier, trier et compter les pièces avant d'essayer d'assembler

-Les goujons de compression sont taraudés avec un Marteau

-Les glissières sont marquées d'un R (droit) et d'un L (gauche) pour un bon placement

-Assurez-vous toujours de faire face la pointe situé sur le haut de la Serrure de Came vers le bord extérieur

-Utiliser tous les clous fournis pour le panneau arrière et les répartir également

-Le panneau arrière doit être utilisé pour vous assurer que votre appareil est robuste

-N'utilisez pas de produits chimiques agressifs ou de nettoyeurs abrasifs sur cet appareil

-Ne jamais pousser, tirer, ou faire glisser votre meuble

Avant de Commencer (page 3)

-Lisez attentivement chaque étape et suivez le bon ordre

-Séparez et comptez toutes vos pièces et matériaux

-Donnez-vous suffisamment de place pour l'assemblage

-Avoir les outils suivants: tournevis à tête plate, #2 tournevis Phillips, et Marteau

-Attention: Si vous utilisez une perceuse électrique ou un tournevis électrique pour visser, veillez à ralentir et arrêter lorsque la vis est bien serrée. Le non-respect de cette consigne peut endommager la vis.

Système de Fixation de Came (page 3)

Ce Système de Fixation de Came sera utilisé tout au long de l'assemblage

Pages 13, 14, 17

Tourner la vis dans le sens des aiguilles d'une montre pour serrer les pièces ensemble.

Page 15

Remarque :

Assurez-vous d'utiliser la vis n° 6 pour cette étape!

La vis n° 7 a une tête et un corps plus grands.

Page 19

Remarque :

Assurez-vous d'utiliser la vis n° 7 pour cette étape!

La vis n° 7 a une tête et un corps plus grands.

Page 22

Pour la maçonnerie, le béton ou d'autres matériaux muraux :

Consultez votre quincaillerie locale pour connaître les ancrages appropriés afin d'arrimer solidement le support de sécurité.

IMPORTANT : CETTE UNITÉ DOIT ÊTRE FIXÉE AU MUR POUR AIDER À PRÉVENIR LE BASCULEMENT. SUIVEZ CES INSTRUCTIONS POUR INSTALLER LE SUPPORT DE SÉCURITÉ ANTI-BASCULEMENT FOURNI AVEC CE PRODUIT.

MISE EN GARDE

Des blessures par écrasement graves ou mortelles peuvent survenir à la suite du basculement d'un meuble.

Pour prévenir le phénomène de basculement :

- * Installez le dispositif anti-basculement fourni ;
- * Placez les articles les plus lourds dans les tiroirs les plus bas ;
- * Sauf si le meuble a été spécialement conçu pour accueillir un téléviseur, ne placez pas de téléviseurs ou d'autres objets lourds sur le dessus de ce produit ;
- * Ne laissez jamais les enfants grimper ou s'accrocher à des tiroirs, des portes ou des étagères ;
- * N'ouvrez jamais plus d'un tiroir à la fois.

L'utilisation de dispositifs de retenue anti-basculement peut seulement réduire, mais pas totalement éliminer le risque de basculement du meuble.

OPTION 1 : Fixation à un goujon d'ancrage mural (méthode préférée)

À l'aide d'un télémètre, localisez un goujon dans le mur. Placez votre unité contre le mur, avec le support de sécurité aligné à cet endroit. Pour faciliter l'insertion de la vis, vous pouvez percer un trou pilote de 1/8" de diamètre (3 mm) à travers le support de sécurité, dans le goujon. Enfoncez la vis à travers le support de sécurité dans le goujon d'ancrage.

OPTION 2 : Fixation à une cloison sèche

Décidez où vous souhaitez placer votre unité contre le mur et marquez cet emplacement à travers le support de sécurité, puis déplacez votre unité de côté. Percez un trou de 3/16" de diamètre (5 mm) dans le panneau mural. Appuyez sur l'ancrage mural dans le trou jusqu'à ce qu'il soit bien en place. Placez votre unité à cet endroit et fixez le support mural à l'ancre murale avec la vis.

Page 23

CHARGES MAXIMALES

Cette unité a été conçue pour supporter les charges maximales indiquées. Le dépassement de ces limites de charge pourrait entraîner un affaissement, une instabilité, un effondrement du produit et/ou des blessures graves.

Attention : Risque de blessures pour les personnes. Ne placez pas de télévision sur ce meuble. Cette unité n'est pas approuvée pour une utilisation avec une télévision.

Page 24

Enregistrez votre produit pour recevoir les éléments suivantes:

- * Détails sur les nouvelles tendances - un aperçu sur les nouveautés
- * Sondages - avoir une voix au sein de notre communauté
- * Offres exclusives et codes promo
- * Service de pièces de rechange rapide et facile

Pour enregistrer votre produit, visitez ameriwoodhome.com

5 Étoiles

Visitez le site Web de votre détaillant local, évaluez votre produit acheté et laissez-nous quelques commentaires !

Nous tenons à offrir un grand "Merci" à tous nos clients pour avoir pris le temps d'assembler ce produit "Ameriwood Home", et de nous donner vos commentaires précieux.

Merci